

**FALCON FABRICATORS NASHVILLE**  
**MODEL FFM-1 ROTARY MARINATOR -- 115V**  
**OPERATION AND MAINTENANCE MANUAL**

---

SECTION 1 .....DESCRIPTION

SECTION 2.....UNPACKING AND SET UP

SECTION 3.....OPERATION

SECTION 4.....CLEANING

SECTION 5.....MAINTENANCE

SECTION 6.....TROUBLESHOOTING

SECTION 7.....SPARE PARTS

SECTION 8 .... .WARRANTY



---

Throughout this manual, **WARNINGS**, **CAUTIONS**, and **NOTES** are used to emphasize information about a procedure that is particularly important or safety related. The meaning of each is described below:

**WARNING**

A **WARNING** is used to emphasize a procedure, step, or practice which, if not correctly followed, could result in personal injury.

**CAUTION**

A **CAUTION** is used to emphasize a procedure, step, or practice which, if not strictly followed, could result in equipment damage.

**NOTE**

A **NOTE** is used to highlight additional information concerning a procedure or condition.

**Falcon Fabricators Nashville**  
**422 Allied Drive**  
**Nashville, TN 37211**  
**800-883-5555 or 615-832-0027**

**WARNING**

*Always use extreme caution when working with rotating equipment. Read and understand this manual before using the FFM-1. Failure to follow the procedures in this manual could result in serious injury and/or electrical shock.*

**1. DESCRIPTION**

The FFM-1 Rotary Marinator is a rotating chicken marinator with a drum capacity of 80 pounds (chicken + marinade). The major components of the FFM-1 are shown in Figure 1 below. The Coupling Adapter (1) transmits torque and absorbs shock between the motor drive shaft and marination drum. The Support Block (2) supports and acts as a bearing for the right side of the marination drum. The Marination Drum (3) holds the chicken and marinade solution and is sealed with the Lid Gasket (4) and easily removable Lid Assembly (5). The Start Button (6) energizes the motor that rotates the drum. It also starts a timer that will automatically stop the drum rotation after 15 minutes. The Stop Button (7) provides a means to stop the drum rotation at any time. It is intended for emergency use only since it also resets the timer. After the drum has stopped, it is emptied into perforated and unperforated drain lugs (8 & 9) slid under the drum on the brackets provided. These drain lugs are not included with the marinator and must be ordered separately.

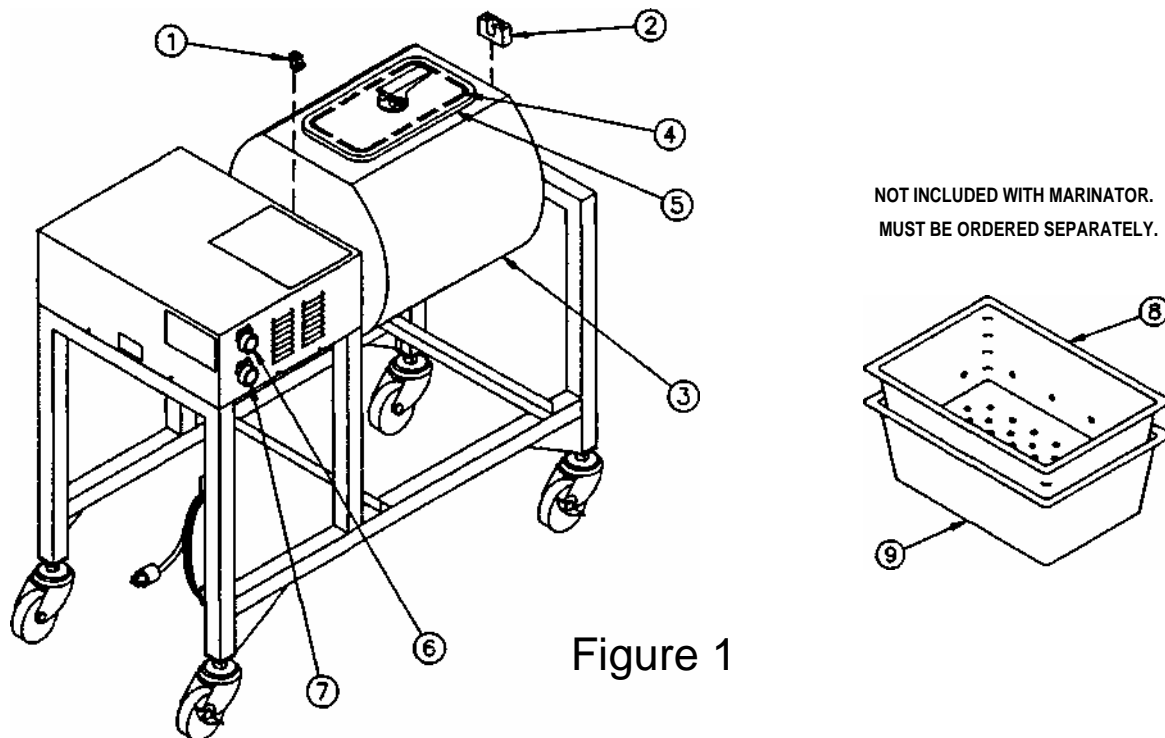

Figure 1

## 2. ASSEMBLY AND SETUP

1. Inspect unit and insure that no parts were damaged in transit. If damage is evident, file claim with freight company that delivered unit.
2. Clean and sanitize unit following procedures in Section 4 of this manual.

## 3. OPERATION

1. Prepare chicken pieces for marination per your established procedures. The FFM-1 Marinator can marinate up to 20 heads at once.
2. Make sure both drain lugs are in place beneath drum.
3. Place loose chicken pieces into drum. Don't fold wings.
4. Mix marinade solution according to directions on packet and pour into drum. Add extra water if called for in your established procedures.
5. Place lid gasket around drum opening.
6. With handle pointing up, place lid assembly over drum opening and turn handle 90° to engage latching bar. Press handle flat to lock lid onto drum.
7. Rotate drum by hand so lid is down and check for leaks. If leaking, remove lid assembly and insure all parts are assembled as shown on motor cover decal. Check lid gasket and latching bar "O" ring for cuts or damage.
8. Position unit out of traffic areas where drum is free to rotate and engage two wheel brakes provided.
9. Plug power cord into 110 -120 VOLT, 60Hz GROUNDED outlet.

### WARNING

***Failure to use a properly grounded outlet could result in serious electrical shock. Tampering with or altering the prongs on the power cord plug will void the unit's warranty and could result in serious electrical shock.***

OPERATION (Continued...)

10. Push START button. Drum will stop automatically after preset time. To stop rotation at any time, push STOP. To change preset time, unplug marinator and remove motor enclosure cover, Adjust timer dial to desired time. Replace motor enclosure cover.

**NOTE**

*When STOP button is pushed, the timer resets.*

11. IMMEDIATELY after drum has stopped, remove lid, rotate drum by hand, and dump chicken into perforated drain lug. Package for storage and store in walk-in cooler per your established procedures.

**NOTE**

*Chicken will spoil if left in marinator drum after marination is complete.*

12. Clean and sanitize drum, lid gasket, lid assembly, and drain lugs .

4. CLEANING

1. Remove drum from unit by lifting its right side and then moving it to the right to disengage left side drive coupling. Remove lid gasket from drum opening.
2. Take lid assembly apart by removing spring-ball pin.
3. Wash and sanitize drum, lid gasket, and all lid parts.
4. Wash and sanitize both drain lugs.
5. Wipe off marinator frame, motor enclosure, and wheels with a sanitized towel.
6. Put lid assembly back together (refer to decal on motor cover). If parts are not assembled exactly as shown, lid will leak.
7. Place drain lugs and drum back on unit. Turn drum opening down so water will drain. Place lid assembly in drain lug until needed .

**CAUTION**

***NEVER use hose to clean marinator frame.  
DO NOT store marinator in walk-in cooler  
since moisture in cooler will damage  
internal electrical components.***

## 5. MAINTENANCE

1. Periodically, when wear is evident, replace coupling spider, bearing block, lid gasket, and latching bar "O" ring.
2. With unit unplugged, periodically remove motor enclosure and vacuum dust from louver screens at each end of enclosure. Also, vacuum dust from vent openings in motor.
3. The motor bearings and gear case are permanently lubricated and do not require periodic lubrication. If, for some reason, lubricant has been lost from gear case, refill with 4 ounces of Hodson #4111 or Gulf Harmony #121 lubricant or equivalent.

### CAUTION

Completely clean old lubricant from gear case before adding fresh lubricant. NEVER mix old and new lubricant.

## 6. TROUBLESHOOTING

### WARNING

***Troubleshooting and repair of the FFM-1 Marinator must be done by trained and authorized personnel ONLY! UNAUTHORIZED PERSONNEL MUST NOT ATTEMPT TO REPAIR THIS EQUIPMENT. Most procedures will require the unit to be energized with the motor enclosure removed. Under these conditions, live electrical components are exposed and there is the possibility of electrical shock. Troubleshooting and repair should only be performed by trained maintenance personnel. Call your maintenance department for assistance, or, if your unit is still under warranty, follow the procedures in Section 8 of this manual.***

# FALCON FFM-1 MARINATOR

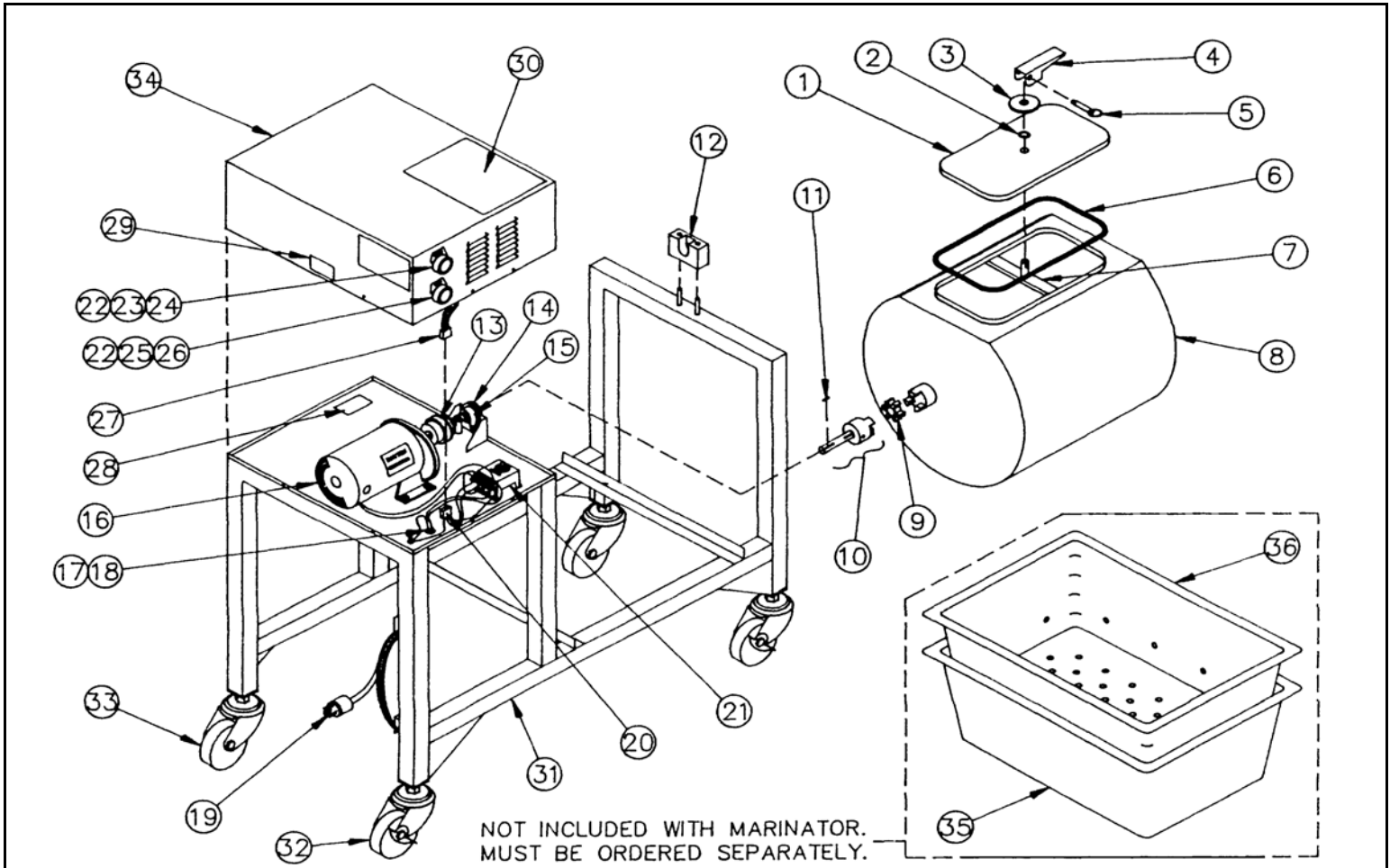

ITEM #	QTY.	PART #	DESCRIPTION
1	1	24-01-222	DRUM LID
2	1	A31-230	LATCHING BAR "O" RING
3	1	66-556	HANDLE BEARING WASHER
4	1	45-01-594	HANDLE
5	1	A31-226	HANDLE RETAINING PIN
6	1	A31-229	LID GASKET
7	1	A31-231	LID LATCHING BAR
8	1	66-308	DRUM
9	1	A31-222	COUPLING SPIDER
10	1	66-306	DRIVE SHAFT ASSEMBLY
11	1	31-01-348	OVERLOAD CLUTCH KEY
12	1	A31-232	RIGHT SUPPORT BEARING BLOCK
13	1	31-01-351	OVERLOAD CLUTCH, 1-12 FT. LBS.
14	1	55-01-075	GROOVED SHAFT SEAL
15	1	A31-179	3/4" PILLOW BLOCK
16	1	10-06-312	40 RPM GEARMOTOR 115 V, 60 HZ
17	1	10-06-145	STRAIN RELIEF
18	1	11-53-003	1/2" LOCKNUT
19	1	75-407	POWER CORD ASSEMBLY
20	1	75-408	TIMER WIRING HARNESS
21	1	67-712	MARINATOR TIMER W/ MTG. PLATE
22	2	10-01-001	PUSH BUTTON START / STOP
23	1	10-06-026	CONTACT BLOCK, NORMALLY OPEN

ITEM #	QTY.	PART #	DESCRIPTION
24	1	A31-307	" START " NAMEPLATE
25	1	10-06-027	CONTACT BLOCK, NORMALLY CLOSED
26	1	A31-306	" STOP " NAMEPLATE
27	1	75-409	COVER WIRING HARNESS
28	1	22-10-217	ELECTRICAL SCHEMATIC DECAL
29	1	22-10-191	DISCONNECT POWER DECAL
30	1	22-10-219	INSTRUCTION AND SAFETY DECAL
31	1	66-559	FRAME AND MOTOR BASE ASSEMBLY
32	1	17-10-070	3" SWIVEL CASTER WITH BRAKE
33	1	17-10-071	3" SWIVEL CASTER WITHOUT BRAKE
34	1	66-309	MOTOR COVER
35	1	A31-255	MAX BOX (NO HOLES)
36	1	A31-256	DRAIN TRAY (HAS HOLES)

FFM-1 MISCELLANEOUS DATA	
OVERALL DIMENSION (WITHOUT MAX BOX AND DRAIN TRAY IN PLACE) 37" H X 37.5" W X 19" D	
MAX BOX AND DRAIN TRAY- 11" H X 18" W X 26" D	
SHIPPING WEIGHT WITHOUT TRAYS-180 LBS.	
SHIPPING WEIGHT WITH TRAYS 190 LBS.	
ELECTRICAL: 115 V , 60 HZ 5A	
MAXIMUM DRUM LOAD-- 80 POUNDS	

## FFM-1 Rotary Marinator, 115V -- Operation and Maintenance Manual

### 8. WARRANTY

#### LIMITED WARRANTY

Unless otherwise specified, Falcon Fabricators, Inc. (Falcon) warrants to the ORIGINAL USING PURCHASER of a new FFM-1 Rotary Marinator that it will be free of defects in materials or workmanship under normal use as follows:

For a period of 90 days from date of Falcon's invoice, Falcon will pay the reasonable and customary labor charges of a service technician AUTHORIZED BY FALCON to repair the defective marinator.

For a period of 1 year from date of Falcon's invoice, Falcon, after confirming a defect in materials or workmanship, will issue a refund or credit (including PREPAID freight charges) for any new or refurbished part purchased from Falcon to replace a malfunctioning part on the invoiced marinator. In order for Falcon to confirm a defect in materials or workmanship, the malfunctioning part must be returned to Falcon for inspection.

To receive warranty service, write down your marinator's model number and serial number and call the Falcon Customer Service Department at 800-251-8521 or 615-832-0027. A Customer Service Representative will verify warranty coverage and issue the required authorization for repair.

All parts and repairs provided under this warranty maintain only the unexpired portion of the original 90 day labor and one year parts warranty.

Marinators or parts that have been subjected to abuse, misuse, accident, improper installation, improper maintenance or repair, and/or unauthorized alteration will not be warranted.

As provided under this warranty, Falcon's liability in all events, shall be limited to repair or replacement of the defective marinator or part therein and shall not exceed the purchase price. Falcon shall not be liable for any incidental or consequential damages. The duration of any and all implied warranties, including the implied warranties of merchantability and fitness for a particular purpose, is limited to the duration of this warranty.

Some states do not allow the exclusion or limitation of incidental or consequential damages, or allow limitations on how long an implied warranty lasts, so the above limitations or exclusions may not apply to you. This warranty gives you specific legal rights and you may have other rights which vary from state to state.

**This warranty is valid only in the United States of America.**

Falcon Fabricators, Inc. offers no warranty, expressed or implied, on used equipment or parts not purchased from Falcon Fabricators Nashville